

# FPGAS AS A CO-PROCESSOR IN IMAGE PROCESSING APPLICATIONS

**BHAVANA SHARMA<sup>1</sup>, V.K. PANDEY<sup>2</sup>, AYUB KHAN<sup>3</sup>**

<sup>1</sup>Assistant Professor, ECE Dept., GLBITM, Greater Noida,

<sup>2</sup>Professor (HOD), ECE Dept., NIET, Greater Noida,

<sup>3</sup>Associate Professor, ECE Dept., Anand Engineering College, Agra,

## ABSTRACT

*The measurement of temperature by using appropriate sensors and controllers is not only important in environmental or weather monitoring but also crucial for many industrial processes. This review covers the study of PLC, microcontrollers and sensors which will be beneficial to readers in understanding the difference between application of PLC and Microcontrollers in controlling temperature. A comparison is also made among three types of smart temperature sensors. A complete analysis is done by using smart sensors with computer support.*

**Keywords: Microcontrollers, PLC, Smart Temperature Sensors.**

## I INTRODUCTION

Temperature is defined as the average energy of microscopic motions of a single particle in the system per degree of freedom. Temperature measurement and control plays a key role in industries and home applications, such as, in boilers [1], greenhouses [2], ovens, rooms [3], LEP2 SC RF cavities [4], turbogas units [5], geothermal power plants [6], weather monitoring [7] etc. it is widely used. To sense temperature, sensors are used. A sensor is a device that measures a physical quantity and converts it into a signal which can be read by an observer or by an instrument, like; a mercury thermometer converts the measured temperature into expansion and contraction of a liquid which can be read on a calibrated glass tube [8].

Temperature monitoring is the process of recording temperature over defined period of time. In previous publications, temperature was monitored with the help of data loggers. Earlier, development of data logger was done through manual measurements from analog instruments. Unfortunately, the data logger was not able to fulfill the requirements of present scenario in terms of time and accuracy. A further development in data logging took place in early 1990s, after which researchers began to design PC based data logging systems [9]. In later stages of development, it was seen that microcontrollers proved to be a reliable and efficient controller [10]. A revolutionary change was seen by use of microcontrollers in embedded system designs. But microcontrollers were difficult to program and cannot be used in harsh environmental conditions. So, PLCs [11] were introduced to overcome the problems of microcontrollers [12].

Temperature control is a process in which change of temperature of a space (and objects collectively there within) is measured or otherwise detected, and the passage of heat energy into or out of the space is adjusted to achieve a desired average temperature [13]. The scope of this review is to analyze various methods used in control and measurement of temperature.

## II OVERVIEW OF CONTRIBUTIONS

In early 1990s, data loggers were used in temperature monitoring applications [9]. With the advancement in technology, microcontrollers were implemented in the field of monitoring [24]. But, microcontrollers performance gets affected by external factors like humidity, temperature variations etc [1]. All these factors led to development of PLC as a controller. PLCs are reliable in harsh environment and are designed to handle many inputs and many outputs [11]. PLCs are easier to program than microcontrollers [12].

**TABLE I**  
**SYSTEM ANALYSIS**

Representative	Sensor applied	Controller applied
Doc. Dr.RN, Dr. Katedra [8]	DS 1820 SMT 160-30 LM 35	PIC 16C65A
R . Brun, E. Ciapala, M. Pirotte [4]	PT 100	80C52
T. P. Mote, Dr. S. D. Lokhande [17]	LM 35	89S52
Goswami, T. Bezboruah, K.C. Sarma [22]	LM 35	AT 89S52
A.T. Karuppiah, Azha Periasamy, P. Rajkumar [14]	LM 35	PIC 18F452
Aman Soni, Debashish Singh Deo [6]	LM 35	OMRON PLC
Tabinder Akter ,Md. Fazlul Huq, Farzana Alam [23][7]	SMT 160	PIC 16F877A
Dogan Ibrahim [15]	LM 35DG	PIC 16F84
M.P. Joshi [13]	LM35 PT100	89C51RD2
Bogdan Levarda, Cristina Budaciu [16]	LM335	PIC18F4620

TABLE I describes about different types of sensors and processing elements used in various systems of temperature measurement and control. The following points briefly describes about the above mentioned systems-

- The sensor LM 35 can be combined with microcontrollers like PIC18F452, AT89S52 and PLCs. The use of LM 35 with PIC18F452 controller [14] provides a system which is useful in measurement and control of high temperature applications like in boiled water temperature measurement [14] and in industries to control high temperature. LM 35 can also be used with AT89S52 controller for water temperature control, control of room temperature and light [17] [22] by using ANFIS (adaptive neuro fuzzy inference system) and comparing output of the system with PID controller, neural network controller [17]. LM 35 functions with PLC for usage in geothermal power plants [6]. LM35 is low cost, highly effective and efficient in usage [6]. 89C51RD2 is interfaced with LM35 sensor to control the variation of ambient temperature [13]. This system is used in pharmaceuticals and in ayurvedic medicine manufacturing [13].

- LM35DZ, a modified version of LM 35 sensor is used with PIC16F84 microcontroller for temperature monitoring [15]. PIC16F84 has advantage of using flash memory over the other microcontrollers. Flash memory makes programming easier in high level language [15].
- PT100 is used for high temperature measurement applications like temperature measurement of LEP2 SC RF (LEP2 superconducting radio frequency) cavities [4].
- SMT 160-30 is a compact temperature transducer used with PIC 16C65A to monitor air temperature [8]. SMT 160-30 is also used with PIC16F877A for measurement of temperature of hot plate and weather monitoring system [23] [7].
- LM 335 is a temperature sensor which works at -40 degree centigrade to 100 degree centigrade [16]. LM 335 is interfaced with PIC18F4620 to measure the temperature of laboratories and test rooms [16].

### III EXPERIMENTAL SETUP

The hardware and software description of the embedded system for monitoring and controlling of temperature is described in the following section –

#### 3.1 Hardware Description

Temperature measurement and control system can be divided into following sections-

- Power supply section-The regulated supply section mode made with full wave rectifier, which provides a constant voltage of 5 volts to the circuit and constant voltage of 12 volts to relays.[9]
- Analog to digital conversion section-Since we have to sense analog parameters i.e. temperature and hence we have to use analog to digital converter. We normally opt for ADC0809 [13] as it has 8 channels and is microprocessor compatible ADC. It converts the analog signal of transducer to digital value with respect to reference voltage, which is in most of the cases 2.5 volts. This reference voltage is obtained using TL431, which is programmable shunt voltage reference. With output voltage range 2.5-36 volts and works like zener diode for the conversion.ADC requires a reference frequency, which is supplied by astable oscillator. In most of the cases, the astable oscillator is 555 IC. The conversion frequency is kept around 150 Khz. Sensors used for temperature is LM 35 [6], PT100 [10] [8] and RTD [13]. These sensors are calibrated in degree centigrade and are linear in our working range with 0.5 degree centigrade of accuracy [9].
- Control section-The analog value is converted to digital value by ADC and is picked up by microcontrollers such as AT89S52 [21], which is a 40 pin device. The AT89S52 is a low power, high performance CMOS 8-bit microcomputer with 8k bytes of flash memory (EPROM) [16].
- Display Section - A liquid crystal display is used to display the data we get from microcontroller or PLC. It is a 2X16 line display [18] [19].
- Temperature Control Section - This section consists of 12 volts relay control hardware connected to various types of cooling elements such as fans, heating elements etc [20][21].

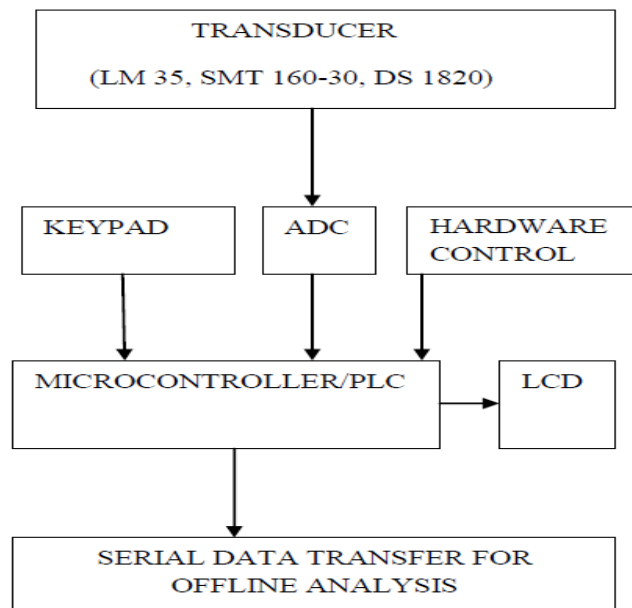

**Figure 1: Block Diagram for Experimental Setup [9]**

### 3.2 Description

A review of researches on temperature measurement and control shows that systems are developed considering the accuracy and cost effectiveness. Temperature control is mainly divided into three sections-

- Sensing elements [8]
- Data processing elements [18]
- Temperature Controlling elements [15][10]

#### 3.2.1 Sensing Elements

Sensing elements are the elements that receive a signal or stimulus (as heat or pressure or light or motion etc.) and responds to it in a distinctive manner. Sensors used for temperature control are:

- Thermocouples [8]
- Thermistors [22]
- Resistance temperature detectors [4][13]
- IC temperature sensors [3][16]

With time thermocouples, thermistors, RTDs were replaced by IC temperature sensors like LM 35 [17], SMT 160-30 [23][7], DS 1820 [8]. The mostly used temperature sensor IC's are :

#### 3.2.2 SMT 160-30

Transducer SMT 160-30 is a compact temperature transmitter with output signal in pulse width form, suitable for computer processing [23]. Transducer has 3-pin package with 2 pins for voltage (5 V) and one pin for output signal. Measured temperature is given by-

$$T(w) / T(p) = 0.320 + 0.00470T \quad (1)$$

T=measured temperature

T (w) =width of pulse

T (p) =period of output signal

### 3.2.3 LM 35

Transducer LM 35 is compact temperature transmitter with analog voltage output + 10 mV/°C [14]. Output signal is on the whole range linear and is calibrated on °C. This output signal is ideal for digital signal processing by A/D converter [3].

### 3.2.4 DS 1820

Single circuit smart temperature sensor DS1820 converts temperature in number form and communicates with environment by the one-wire DALLAS bus [8]. Circuit is made on 3-pin or 16-pin package. Sensor can be loaded by voltage through data bus. Final temperature is given by:

$$t = T - 0.25 + (N(j) - N(z)) / N(j) \quad (2)$$

t= final temperature

N (j) = number of oscillations corresponds to 1 degree centigrade

N (z) = number of oscillation cycle corresponds to zero

**TABLE II**  
**COMPARATIVE ANALYSIS**

Temperature sensor	Loading voltage variation	Temperature range
SMT160-30	475-700 volts	(-45) – 130 degree Centigrade
LM35	4-30 volts	(-55) – 150 degree centigrade
DS1820	2.7-5.5 volts	(-55) – 127 degree centigrade

TABLE II gives a comparative overview of IC temperature sensors. The loading voltage requirement is maximum in SMT 160-30 while it is minimum in DS1820. LM 35 is widely used because of its extended working temperature range [8].

## 3.3 Data Processing Elements

Data processing elements are the elements which process the signal provided by transducers [13]. In case of temperature measurement and control, the data processing elements are-

- Microcontroller
- PLC

### 3.3.1 Microcontroller

A microcontroller is a small computer on a single integrated circuit containing a processor, memory, and programmable input/output peripherals. Program memory is also included on chip and a small amount of RAM. Microcontrollers are designed for embedded applications [24].

### 3.3.2 PLC

PLC is defined as programmable logic controller. Unlike general-purpose computers, the PLC is designed for multiple inputs and output arrangements, extended temperature ranges, immunity to electrical noise, extreme weather and resistance to vibration and impact [11]. Therefore, PLCs are preferred over microcontrollers [5] [12].

### 3.4 Temperature Controlling Elements

Controlling elements are used to control the temperature of the surroundings. There are two types of controlling elements- heating elements and cooling elements.

## IV RESULT ANALYSIS

The various systems formed by using temperature sensors and controllers have its own merits and demerits. The result analysis of such systems is given by TABLE III.

**TABLE III**  
**RESULT ANALYSIS**

REPRESENTATIVE	SETUP	RESULTS
Doc. Dr. RN, Dr. Katedra [8]	Sensors SMT 160-30 and LM 35 with microcontroller PIC16C65A	The system performs different tasks such as high level computation, smart sensor configuration data recording, global test
R . Brun, E. Ciapala, M. Pirotte [4]	Sensor PT100 with microcontroller 80C52	The system gives result up to 2% of accuracy
T. P. Mote, Dr. S. D. Lokhande [17]	Sensor LM 35 with microcontroller 89S52	The ANFIS controller showed 15% better results than PID controller and 5% better than neural network
Goswami, T. Bezboruah, K.C. Sarma [22]	Sensor LM 35 with microcontroller AT89S52	This type of embedded system is widely used in industry due to its low cost and high efficiency
A.T. Karuppiah, Azha Periasamy, P. Rajkumar [14]	Sensor LM 35 with microcontroller PIC18F452	This type of system is used to control high temperature in industrial application
Aman Soni, Debashish Singh Deo [6]	Sensor LM 35 with Omron PLC	This type of system is very useful in monitoring temperature in remote areas
Tabinder Akter, Md. Fazlul Huq, Farzana Alam [7][23]	Sensor SMT 160-30 with microcontroller PIC16F877A	This type of system are very accurate (up to 2%) and at the same time cost effective also
Dogan Ibrahim [15]	Sensor LM 35DG with controller PIC16F84	The system has fast response as high level language is used

M.P. Joshi [13]	Sensors LM 35 and PT100 with controller 89C51RD2	The use of microcontroller can make the system very compact, reliable and very accurate
Bogdan Levardam, Cristina Budaciu [16]	Sensor LM 335 with microcontroller PIC18F4620	This is low cost application with user friendly system

#### IV CONCLUSION

A framework has been presented that incorporates the use of sensors in developing low cost and high accuracy temperature control system using analog and digital components. The performances of sensors are distinguished on the basis of their accuracy. The accuracy indicates how closely the sensor can measure the actual or real world parameters.

Besides , a comparison on the features of different types of monitoring system has been carried out and it concludes that the use of microcontroller makes the system very compact , reliable and very accurate to achieve precise output with real time signals and PLC is beneficial where reprogramming is required and additionally it require minimum maintenance.

#### REFERENCES

- [1] Narong Aphiratsakun , Virach Wongpaibool And Kittiphan Techkittiroj, A Review On Temperature Process Control : Case Study On Boiler, Department Of Mechatronics Engineering ,Bangkok , Thailand , July 2011.
- [2] P. A. Saudagar , D. S. Dhote , D. R. Solanke, Microcontroller Based Intelligent Temperature Controller For Greenhouse, Volume 1, International Journal Of Engineering And Science, December 2012.
- [3] Theophilus Wellam , Bhudi Stiaawan, A Mcrocontroller based Temperature Monitoring System, Volume 53, International journal of computer applications, September 2012
- [4] R. Brun, E. Ciapala, M. Pirotte, A Microcontroller Based Temperature Measurement Module For The LEP2SCRF Cavities, CERN, Geneva, Switzerland. September 2005.
- [5] Salvador Delara-Jayme, Marino Sanchez-Parra, Luis Castelo Cuevas, PLC Based Control System For Turbogas Units, Division Of Control Systems, GCI 29-1 IIE Temixco, Morelos , September 2003.
- [6] Aman Soni, Debashish Singh Deo, Geothermal Power Plant Design Using PLC And SCADA, Volume 4, International Journal Of Scientific And Engineering Research, May 2013.
- [7] Kamarul Ariffin Noordin, Chow Chee Onn and Mohammad Faizal Ismail, A Low Cost microcontroller based weather monitoring system, Volume 5, CMU journal (33),2006.
- [8] Doc Dr. RN, Dr., Listopadu, Smart Temperature Sensors For Measurement And Control, Session 4, International Scientific Conference Of FME: Automation Control And Applied Informatics, 1997.

- [9] A. Goswami, T. Bezoruah And K.C. Sharma, Design Of An Embedded Systems For Monitoring And Controlling Temperature And Light, Volume 1 International Journal Of Electronic Engineering Research, March 2009.
- [10] Ljubivoj Cvitas, Zeljiko Hocenski, Increasing Accuracy Of Temperature Measurement Based On Adaptive Algorithm For Microcontroller Transmitter, Department Of Electrical Engineering, Polytechnic Of Zagreb, Konavosaka, Croatia. , May 2008.
- [11] Kaushik Bhuiya, Kintali Parekh And Kilaru Laxmi Sahiti, Low Cost Wireless Control And Monitoring Using PLC And SCADA, Volume 3, International Journal Of Scientific And Research Publications, September 2013.
- [12] D.V. Pushpalatha, K.R. Sudha And Swati Devabhaktuni, Millienium3 PLC Based Temperature Control Using LM35, Volume 2, Research Journal Of Engineering Sciences, June 2013.
- [13] M.P. Joshi, Real Time Cost Effective Temperature Controller, Volume 3, International Journal Of Electronics And Communication Engineering And Technology, September 2012.
- [14] A.T. Karuppiah, Azha Periasamy, P. Rajkumar, Boiled Water Temperature Measurement System Using PIC Microcontroller, Volume 2, International Journal Of Advanced Research In Electrical, Electronics And Instrumentation Engineering, June 2013.
- [15] Dogan Ibrahim, Monitoring Temperature Using A Microcontroller With High Level Language, East University, PK670, Lefkosa, TRNC, June 2004.
- [16] Bogdan Levarda And Cristina Budaciu, The Design Of Temperature Control System Using PIC18F4620, University Of Technology Gheorghe Asachi Din Iasi Tomul, February 2010.
- [17] T. P. Mote, Dr. S. D. Lokhande, Temperature Control System Using ANFIS, Volume 2, International Journal Of Soft Computing And Engineering (IJSCE), March 2012.
- [18] National Semiconductor Corporation, LM35 Data Sheet Precision Centigrade Temperature Sensors Atmel Data Book, November 2000.
- [19] Atmel Corporation AT89S52 Data Sheet, 8 Bit Microcontroller With 8K Byte Flash, Atmel Data Book, 2000
- [20] M. Kassim, M.N. Ismail and C.K.H. Che Ku Yahaya, A Web Based Temperature Monitoring System, International Journal of Multidisciplinary Sciences and Engineering, Vol. 2, March 2011
- [21] Craig Steiner, Introduction to LCD Programming Tutorial, Vault Information Services LLC, 2005.
- [22] Goswami, T. Bezboruah, K.C. Sarma, Design Of An Embedded System For Monitoring And Controlling Temperature, Porc. Of Interntional Conference On Emerging Technologies And Application In Engineering Technology And Science 13-14 January, Volume 1, Pp 105-110.



[23]. Tabinder Akter, Md. Fazlul Huq, Farzana Alam, Md. Afzalur Rab And Dr. Md. Habibur Rahman, Temperature Control Of Hot Plate Using Microcontroller Based PWM Technique, Volume 12, Global Journal Of Researchers In Engineering Electrical And Electronics Engineering, May 2012.

[24] James S. Mcdonald, Temperature Control Using A Microcontroller : An Interdisciplinary Undergraduate Engineering Design Project, Department Of Engineering Science ,Trinity University, San Antonio, TX78212, April 2003.

IJEEE