



## SMART ATM MACHINE USING REDTACTON TECHNOLOGY

**Chaitanya V. Adgokar<sup>1</sup>, Prof. Sachin Murarka<sup>2</sup>**

*<sup>1,2</sup>Department of Electronics & telecommunication*

### ABSTRACT

*In this project ATM machine will work smart by using the RedTacton technology. RedTacton is a Human Area Network Technology That uses Human Body as a Safe and secure high speed network transmission path. Tacton means "Touch-Act-on" is known as action triggered by touching. RedTacton uses weak electric field on the surface of the body as a transmission medium. A transmission Path is formed at the movement of human body come in a range of RedTacton Transceiver.*

*RedTacton transmitter consists of Dual Tone Multi Frequency encoder. The signal is encoded as pair sinusoidal tones. Which generate valid & invalid signal and can be transmitted through human body to RedTacton receiver for additional processing. According to the particular sequence enhance the security of ATM card, RedTacton based smart ATM card is proposed.*

***Keywords: Microcontroller(89C51), LED, Transformer, Voltag Regulator, Relay, Etc.***

### I. INTRODUCTION

Today, we have seen the technology become highly grow in all the sector of electronics. Hence in parallel side the more security of these various technologies is also important. The RedTacton technology which is used in ATM is also as an part of growing technology an highly secure. We have begun to embellish our body with personal information and communication appliances. Such device including mobile phone, personal digital assistant, etc. but currently there is no such method for these kinds of devices to share data. Networking these kinds of devices can reduce functional input output redundancies and allow new convenience and services. We have seen LAN, WAN, MAN, INTERNET, etc. but here is new concept of REDTACTON which makes the human body as a communication network by name human area network. The human area network (HAN) technology which was introduce by Nippon, Telegraph and Telephone corporation, that uses the human body surface is a high speed and safe network transmission path. RedTacton is a break-through technology that enables the reliable high speed HAN for the 1<sup>st</sup> time. RedTacton can achieve duplex communication over the human body at a maximum speed of 10mbps. The RedTacton receiver senses changes in the weak electric field on the surface of the body caused by the transmitter. RedTacton depend upon the principle that the optical property of an electro optical crystal can vary according to the change of weak electric field, RedTacton detect changes in the optical properties o an electro optic crystal using a lessor and converts the result to an electrical signal in an optical receiver circuit. The transmitter sends data by inducing variation in the minute electric field

on the surface of the human body. Data is received using a photonic electric field sensor that combines an electro optic crystal and a lesser light to detect variation in the minute electric field.

## II. REDTACTON HAS THREE MAIN FUNCTIONAL FEATURES

**Touch:** Touching, gripping, sitting, walking, stepping and other human movements can be the triggers for unlocking or locking, starting or stopping equipment, or obtaining data.

**Broadband & Interactive:** Bandwidth does not deteriorate even with duplex operations and simultaneous access by many users! Duplex, interactive communication is possible at a maximum speed of 10Mbps. Because the transmission path is on the surface of the body, transmission speed does not deteriorate in congested areas where many people are communicating at the same time.

**Any media:** In addition to the human body, various conductors and dielectrics can be used as transmission media. Conductors and dielectrics may also be used in combination

### 2.1 RedTacton Transceiver

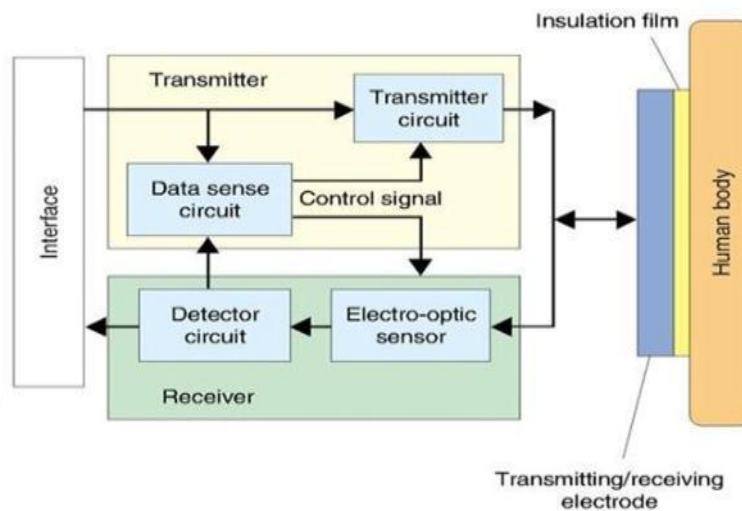
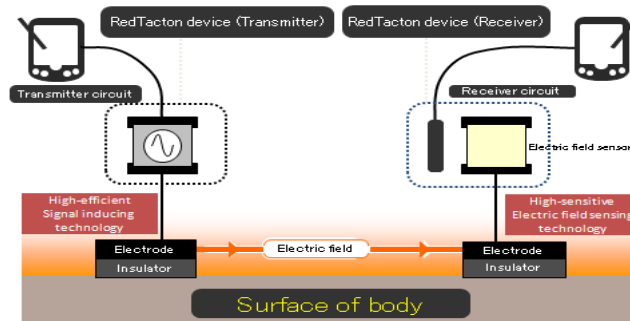

**Fig.1 Block diagram of RedTacton Transceiver**

Transmitter consists transmitter circuit that has electric fields towards the body and a data sense circuit, which distinguishes transmitting and receiving modes by detecting both transmission and reception data and outputs control signals corresponding to the two modes to enable two way communication. Implementation of receive-first half-duplex communication scheme that sends only after checking to make sure that there is no data to receive in order to avoid packet collisions. RedTacton takes advantage of the long-overlooked electric field that surrounds the human body.

### 2.2 Working of Redtacton

RedTacton takes a different technical approach. Instead of depending on electromagnetic waves or light waves to carry data. RedTacton using weak electric fields on the surface of the body as a transmission medium as shown in figure.

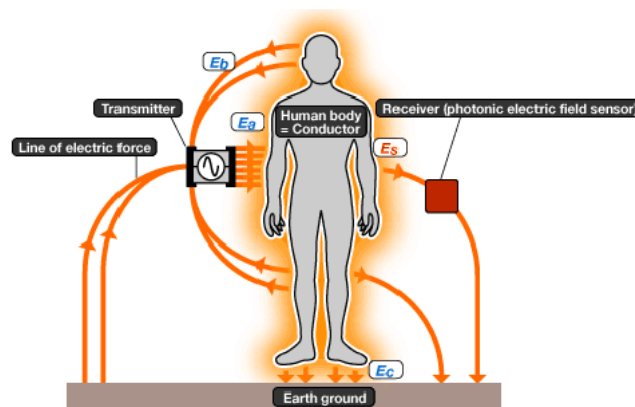

**Fig.2 Working of RedTacton**

- 1) The RedTacton transmitter induces a weak electric field on the surface of the body.
- 2) The RedTacton receiver senses changes in the weak electric field on the surface of the body caused by the transmitter.
- 3) RedTacton relies upon the principle that the optical properties of an electro-optic crystal can vary according to the changes of a weak electric field.
- 4) RedTacton detects changes in the optical properties of an electro-optic crystal using a laser and converts the result to an electrical signal in a optical receiver circuit.

Multiple transceivers can be used simultaneously. The reason is RedTacton uses a proprietary CSMA/CD (Carrier Sense Multiple Access with Collision Detection) protocol that allows multiple accesses with the same medium from multiple nodes.

### III. MECHANISM OF REDTACTON



**Fig.3 Mechanism of Redtacton**

The naturally occurring electric field induced on the surface of the human body dissipates into the earth as shown. Therefore, this electric field is exceptionally faint and not stable. The photonic electric field sensor

developed by NTT enables weak electric fields to be measured by detecting changes in the optical properties of an electro-optic crystal with a laser beam.

### 3.1 Human Safety

The transmitting and receiving electrodes of the RedTacton transceiver are completely covered with insulating film, so the body of the person acting as transmission medium is completely insulated. This makes impossible for current to flow into a person's body from the transceiver. When communication takes place, displacement current is generated by the electrons in the body because the body is subjected to minute electrical fields. Such type of displacement currents are very common everyday occurrences to which we are all subjected. RedTacton conforms to the "Radio frequency-exposure Protection standard (RCR STD-38)" issued by the Association of Radio Industries and Businesses (ARIB).

### Block Diagram

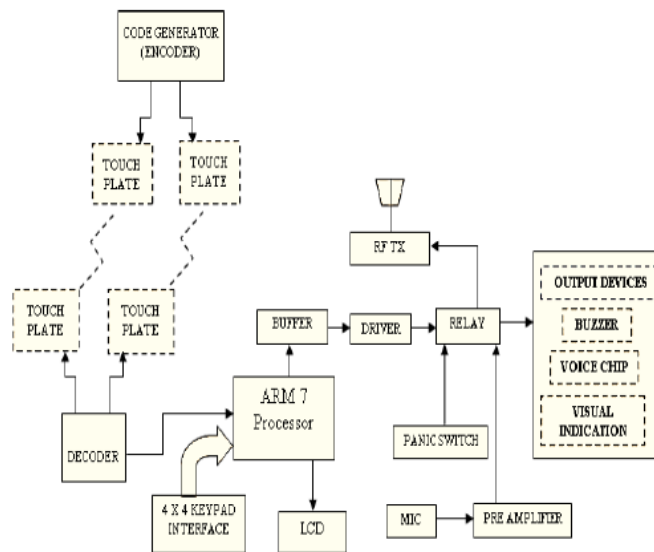

Fig.2 Redtacton Based smart card security for ATM

## IV. METHODOLOGY

The block diagram of RedTacton based smart card security for ATM. It consist RedTacton transmitter, receiver, driver, micro controller unit, voice chip and regulator. RedTacton is a Human Area Network, body of human being used for transmit the signal. It is completely definite from wireless and infrared technology. Communication is possible unit anybody surface such as fingers feet arms, face, legs or hands. RedTacton work through shoes, clothing.

In RedTacton receiver consist of Dual Tone Multi frequency Decoder. It has transmitted signal is identified. As the transmitted signal is a very low voltage, buffer and drivers are used to send the received signal to the electromagnetic switch, electromagnetic switch check they receive signal with the predefined valid code. If an invalid code is received and detected in the switch then the buzzer start ringing indicating that an invalid card is



trying to access the ATM and If valid code is received then only the switch send the signal to the main control unit of an micro controller. If micro controller get active mode, it switches on the keyboard where predefined option are stored to perform various task such as change password, entre password, new password , etc. After entering the valid password the voice bank get activated. In voice bank predefined option with key are present which guide the user to select appropriate action in the ATM such as cash withdraws, account balance, kin change, etc. In this mechanism 89C51 microcontroller is used.

## 4.1 Advantages

- RedTacton does not require the electrode to be in direct contact with the skin.
- Data loss during transfer is less.
- No problem of hackers. It is very hard to pick up stray electronic signal radiating from the body.
- Speed of transmission data is max. of 10mbps.

## V. RESULTS/ CONCLUSION

In such a way that, the proposed RedTacton based smart security card system for ATM has been implemented successfully and is tested on hardware. Experimental result verify successfully and effective develop operation. When we have compare RedTacton technology we can other technologies, it can view a better security since there is no problem o hackers as our body itself acts as transmission media and can be used more in the field where there is a new to upgrade the security in time of high theft rate and it is very useful for future aspect.

## REFERENCES

- [1] Siu/Cheng, Charles, Chang, "Overview of smart card security", 2008.
- [2] Mazidi, The 8051 microcontroller and embeded system
- [3] Teena antil, Pinki, Mrs Soanl Beniwal, "Redtacton : A review" International Journal of SCINTIFIC & Engineering Research, Vol. 4, Issue 3 , March, 2013
- [4] Red Tacton - A Human Area Networking Technology", International Journal of Engineering Trends and Technology (IJETT) - Volume4Issue4- April 2013.
- [5] George Koutitas, Member, IEEE," Multiple Human Effects in Body Area Networks" IEEE Antennas And Wireless Propagation Letters, Vol. 9, 2010.
- [6] Hsueh-Wen Tseng, Member, IEEE, Ruei-Yu Wu, and Yi-Zhang Wu, "An Efficient Cross-Layer Reliable Retransmission Scheme for the Human Body Shadowing in IEEE 802.15.6-Based Wireless Body Area Networks" IEEE Sensors Journal, Vol. 16, No. 9, May 1, 2016