

Power Quality Improvement by Using Unified Power Quality Conditioner

Vinay Kumar Janagama, Lecturer in Electrical and Electronics Engineering,, Government Polytechnic, Kothagudem, India
Srinivasa Rao Jangili, Head of Electronics and Instrumentation Engineering, Government Polytechnic, Kothagudem, India

Abstract— This paper presents literature review for improving the power quality by using the unified power quality conditioner (UPQC). There is a more complex network in the power system, in which generating station is connected with the load center through long transmission and distribution line. For improving the performance of distribution network the new concept came into existence known as custom devices. One of the custom power device is unified power quality conditioner is one of the custom power devices. The different configurations of UPQC system for single phase and three phases are well discussed in this paper. The various researchers have given different names to the UPQC according to their function, topology and application. The various topologies of UPQC explained are, left shunt (UPQC-L), right shunt (UPQC-R), open UPQC, Interlined UPQC (UPQC-I), Modular UPQC (UPQC-ML).

Keywords— Power quality, Harmonic elimination, Unified power quality conditioner, D-STATCOM.

I. INTRODUCTION

Nowadays the end users and electric utilities are focusing on the electric power quality. The power quality issues are not new, but the electric utilities are becoming aware of these quality problems [1]. The main reason for focusing on the quality of electric power is increase in use of electronic loads, which are nonlinear in nature. Mostly, the electronic equipment's used are microprocessor based and they are much sensitive to the electric power quality. The various issues of power quality like voltage swell, sag, interruptions, harmonic current and voltage harmonics are becoming a challenge to the utilities [2]. The current harmonics results into several problems like, Increase in losses of the power system, over heating of conductor, burden of reactive power, malfunctioning of relays, poor power factor. The reason for focusing on the quality of electric power is the economic value. The automatic impacts on quality of electric power on the utilities, customers and suppliers are explained in [1]-[3]. Hence for maintaining the quality of power is always a great task. For mitigating the voltage and current harmonic, voltage swell and voltage sag the active power filter (APF) is one solution. The extensive survey is collected on active power filter in [4]. In this paper, the section II describes the custom power devices; section III explains the various configurations of UPQC, and finally the conclusion.

II. CUSTOM POWER DEVICES

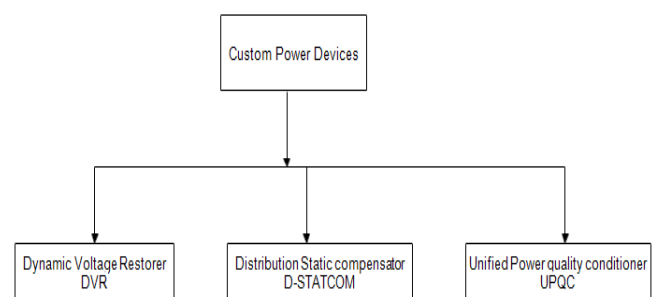

Fig. 1. Different types of custom power devices

Voltage sag from grid affects on the sensitive load. For protection of such sensitive loads, the custom power devices are taken into consideration. Custom power improves the reliability and quality of power, which is delivered to the customers. The improvement in power quality results into low unbalanced supply voltage, harmonic distortion is low, Reduction in flicker of supply voltage, voltage sag and swell are reduced. The custom power devices are shown in above flow chart Fig. 1.

1. Dynamic voltage restorer (DVR)
2. Distribution static compensator (D-STATCOM)
3. Unified power quality conditioner (UPQC)

The main function of DVR is to increase the quality of power. Whereas the D-STATCOM compensates the harmonic and unbalance in current of loads which are nonlinear. The UPQC is the combination of DVR and D-STATCOM. The explanations of custom power devices are given below.

1. Dynamic Voltage Restorer (DVR)

DVR is the custom power device which is power electronic converter based used for improving quality. According to survey [5], [6] the DVR is the device which is economical and suitable solution for compensating the sag in voltage. Along with the sag in voltage compensation, a DVR is used to mitigate load voltage harmonic. The [6] presents one of the control strategies for mitigating the selective voltage harmonics. The power quality problems related to power are eliminated by use of DVR.

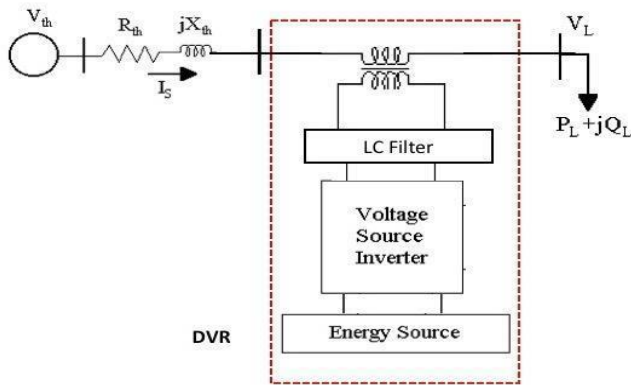

Fig. 2. Dynamic Voltage Restorer (DVR)

The above Fig. 2 shows the series connection of Dynamic voltage Restorer (DVR) to the distribution line. For correcting load voltage, DVR injects the voltage in phase and magnitude by using a coupling transformer. DVR consists of VSI, i.e. voltage source inverter, storage device, coupling transformer, LC filter, series connected coupling transformer. Mostly for storing the energy, capacitor DC link is used. The main important role of DVR is a reduction of voltage sag, which causes damage of sensitive load.

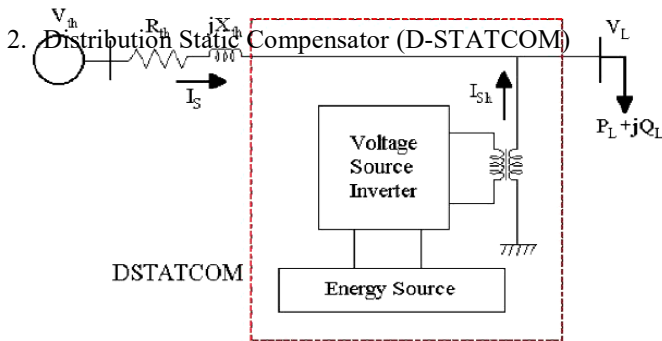

Fig. 3. Distribution static compensator (DSTATCOM)

The variation in voltage like, voltage sag, swell, flicker in voltage is minimized by using the static compensator (STATCOM). The STATCOM used in the distribution side is called as DSTATCOM [7], [8]. By use of the coupling transformer the DSTATCOM is connected in parallel to the line as shown in Fig. 3.

The main function of DSTATCOM is to eliminate all the load harmonics, which are given to the supply. The DSTATCOM connected in parallel to the load acts as a current source. DSTATCOM has the capacity to absorb as well as inject the reactive power very vastly. The main functions of DSTATCOM are compensation of reactive power, mitigating harmonic, improving power factor.

3. Unified Power Quality Conditioner(UPQC)

Many researchers [9]-[11] have studied one of the ways for improving quality of power by using unified power quality

The use of separate shunt and series active power filter may not be economical. Hence, the Moran [12] introduced one of the devices combining both shunt and series active filter. After that the Akagi and Fujita [13] developed the concept of UPQC. After this, many of the researchers used this concept of UPQC.

The Fig. 4. Represents the unified power quality conditioner.

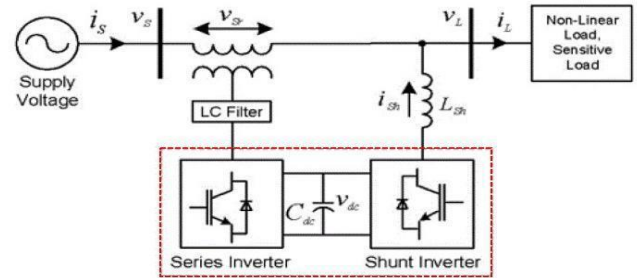

Fig. 4. Unified power quality conditioner

The various components used in UPQC are as follows:

1. Series inverter - The inverters connected in series to the supply known as the series active filter. This inverter behaves as a voltage source line which eliminates a voltage interruption.
2. Shunt inverter - The inverter connected in shunt to the supply line is known as shunt active filter. It eliminates the current related harmonics also minimize the reactive current in the load circuit.
3. DC link - The capacitor or inductor can be used as common DC link. As shown in fig. 4 the capacitor is used as DC link, which supplies the DC voltage.
4. LC filter - The output of the series active filter produces high switching ripples. The LC filter minimizes the ripples in a system. The LC filter acts as the low-pass filter.
5. L_{sh} Filter - The L_{sh} filter acts as a high-pass filter. The ripples during switching mode are minimized by L_{sh} filter.
6. Injection transformer -The series injection transformer connected to series converter.

III. VARIOUS CONFIGURATIONS OF UPQC

The classification of UPQC depends upon the-

- 1) Topology of converter
- 2) Supply system
- 3) Configuration of system
- 4) Voltage sag compensation

The classifications of UPQC above given are explained below:

- 1) Classification on topology of converter

The classification on topology is divided into two types, i.e. Voltage source inverter and current source inverter.

- a) Voltage source inverter:

One of the topology of UPQC is VSI i.e. voltage source inverter based UPQC. The VSI is controlled by pulse width modulation (PWM). There is the energy capacitor for storing the energy. The Fig. 4 Shows the UPQC based on VSI with

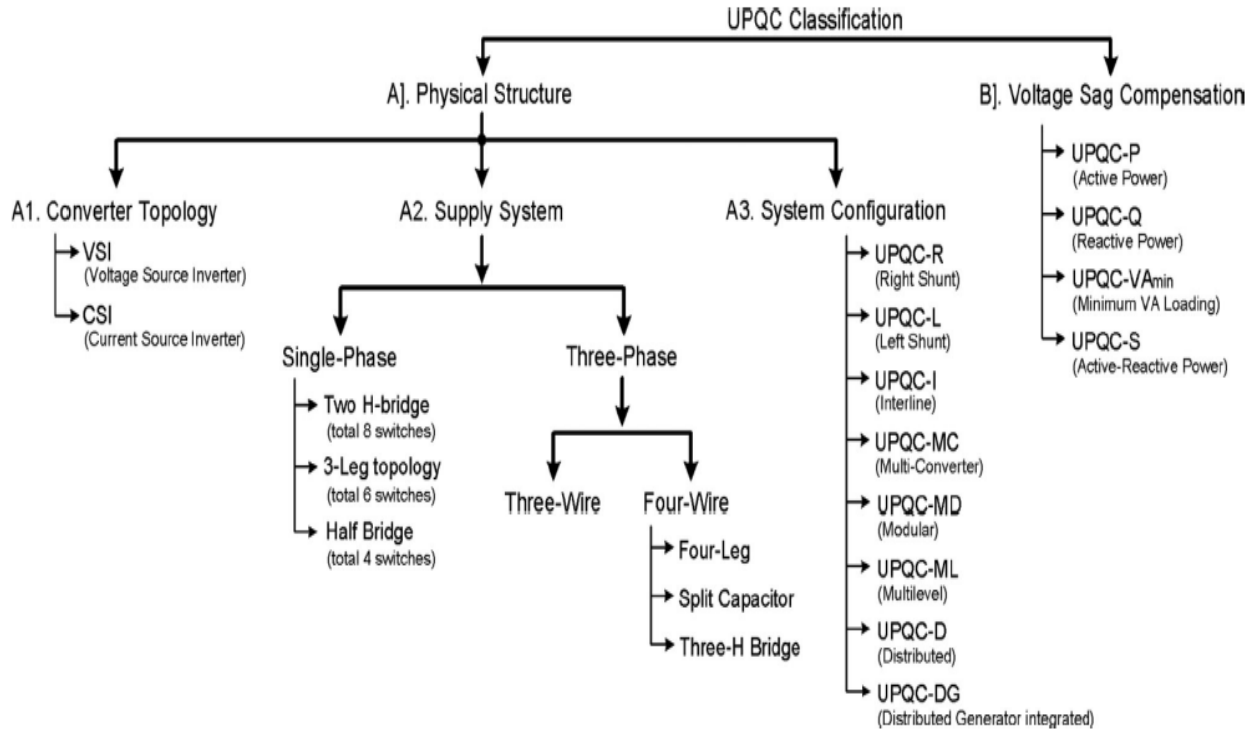

Fig. 5. Classification of UPQC

based devices are preferred as there is common DC link for storing the energy [14]. Also some of the advantages of UPQC based on VSI are it can be expanded up to multilevel converter, chain converter or multi step converter for improving the performance where the frequency switching is low and the handling capacity of power is increased, Overall control is flexible, blocking diodes are not needed, light in weight, cheaper.

b) Current source inverter

The UPQC is developed by using the modulation of the Pulse width (PWM) current source inverter (CSI) [14]. The Fig. 6. Shows the UPQC based on the current source inverter. In this the inductor L_{dc} stores the energy, and it acts as a common DC link.

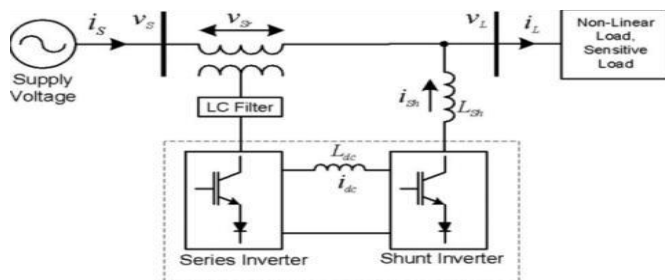

Fig. 6. Current Source Inverter

2) Classification on supply system

The Classification of UPQC depending on the supply system is further divided into single-phase and three-phase supply system [15]. Further the Single and three phase can be

Classified as single phase two wire and three phase three wire or three phase four wire System.

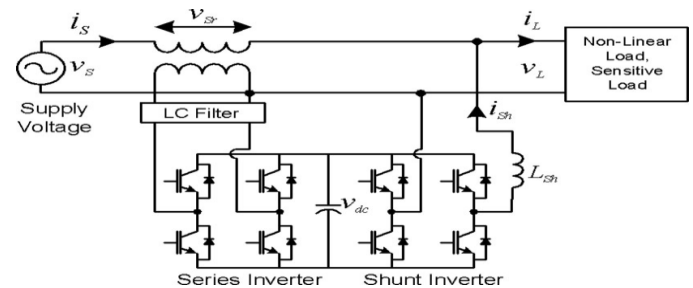

Fig. 7. Configuration of H- Bridge (1P2W)

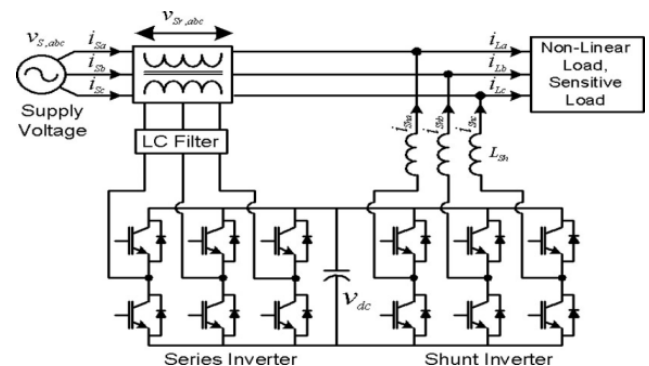

Fig. 8. UPQC of three phases three wires (3P3W)

The problems of power quality related to voltage harmonics are same in three phase and single phase system. But in the system of a three phase the compensation in unbalance of

voltage is required. The problems related to Current harmonics and reactive current of load are issues in the system of single phase [16]. The unbalance in the current is considered in the system of 3P3W. Also it needs the compensation of neutral current [15], [16]. For Minimizing the problems related to power quality are compensated by configuration of UPQC into the 1P2W system it consists of two inverters of H-Bridge with total eight switches.

This Configuration is based on VSI [17], [18]. The reduction part in the configuration of single phase UPQC is described in [17] by using three, six and four switches as shown in Fig. 7 and Fig. 8.

3) Classification on configuration of system

As compared to other devices, UPQC performs the two activities at the same time i.e. minimizes voltage disturbances as well as the current disturbances. The system configuration is one of the classifications of UPQC. Different configurations of UPQC are explained in this section.

a) Right and left shunt UPQC

The two inverters are connected Back to back in UPQC. Hence we can classify the UPQC based on the location of a shunt inverter in connection with series inverter. The shunt inverter placed at the right side is named as the right shunt UPQC (UPQC-R) [13], where as the shunt inverter placed at the left side called as the left shunt UPQC (UPQC-L) [19]. The configuration of UPQC-R is represented in Fig. 4.

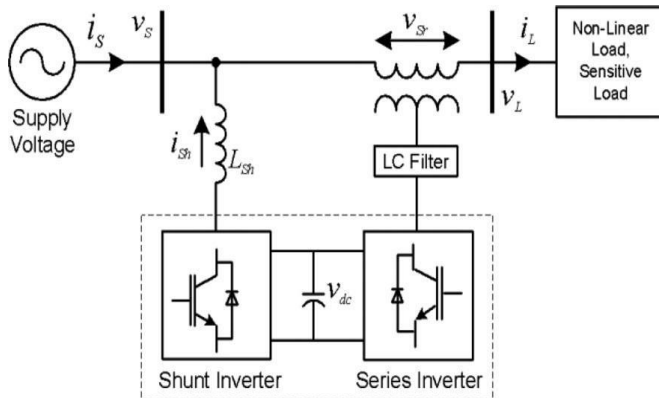

Fig. 9. System configuration of UPQC-L

The Fig. 9 shows the configuration of UPQC-L. Out of these two configurations, the UPQC-R is used significantly. The sinusoidal current flows from the series transformer in UPQC-R. This sinusoidal current is not same as that of load current. In this configuration, the shunt inverter minimizes the current harmonics. In some cases, the UPQC-L is used, such as for minimizing a difficulty between passive filter and shunt filter.

b) UPQC Interlined (UPQC-I)

Joshi A. et al. [20] explained one of the interesting configurations of UPQC. In this configuration, the shunt and series inverter are placed in the middle of two distribution feeders. This is known as UPQC interlined (UPQC-I). In this configuration, one feeder is joined with series inverter, and second feeder is joined with shunt inverter. In this

configuration the regulation of the two feeders is simultaneous.

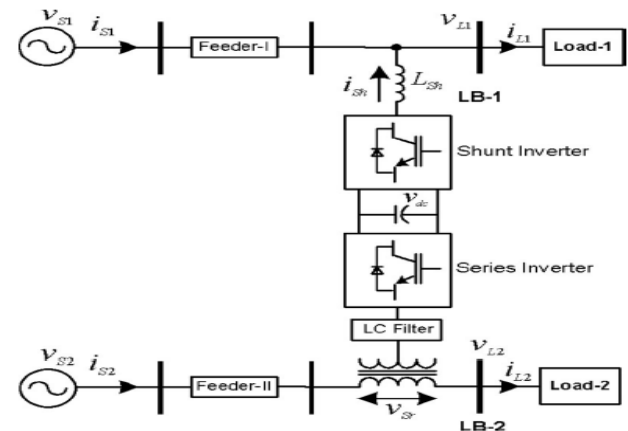

Fig. 10. system configuration UPQC-I

c) UPQC Multiconverter (UPQC-M)

The improvement in performance of a system, the researchers have evaluated of adding the third unit of a converter for supporting the DC bus. M.C. Wong et al. [21] have done research on use of battery storage and super capacitor for improving the capacity. The connection of third converter can be done in different ways like it can be connected in parallel with the feeder, or adjacently it can be connected in series with the feeder.

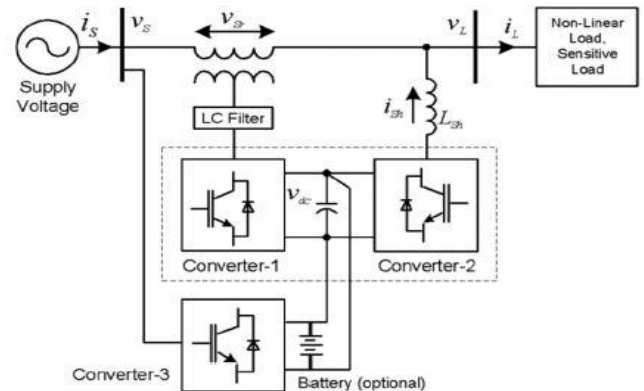

Fig. 11. System configuration of UPQC-M

d) UPQC Modular (UPQC- Modular)

The Fig. 11 shows the configurations of UPQC Modular (UPQC-M). This configuration was introduced by the researcher Bae et al. [22]. This configuration is obtained by connecting numerous H-bridges i.e. several UPQC in cascade for each phase. In [23] by use of multi terminal winding transformer the modules of H-bridge of shunt side of the UPQC are lined in series, whereas the modules of H-bridge of series side the UPQC is linked directly in series without using the series transformer. If the number of modules goes on increasing, the voltage of each H-bridge will get reduced.

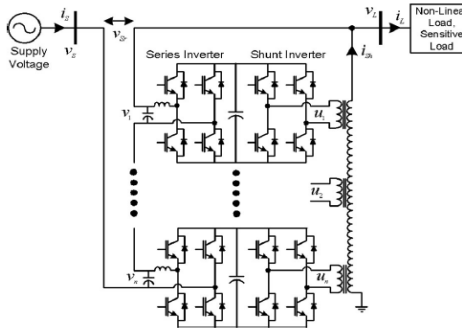

Fig. 12. System configuration of UPQC-Modular

e) UPQC Distributed Generator (UPQC-DG)

The renewable-energy sources such as wind, solar are preferred nowadays as alternate sources. The DG sources can be combined to the UPQC [23]. This total topology is called as UPQC-DG. In this configuration, the DG sources are connected to DC link. The voltage and current harmonics are mitigated and also the regulation of DG power is done by UPQC. The generated power by DG can be stored in battery as the backup in DG bus. One more benefit of giving power to the load during voltage interruptions is done by the UPQC integrated with DG. Next the power of DG is given in interconnected mode, i.e. to the load as well as to the grid or islanded mode in this the power is transferred to the selective loads.

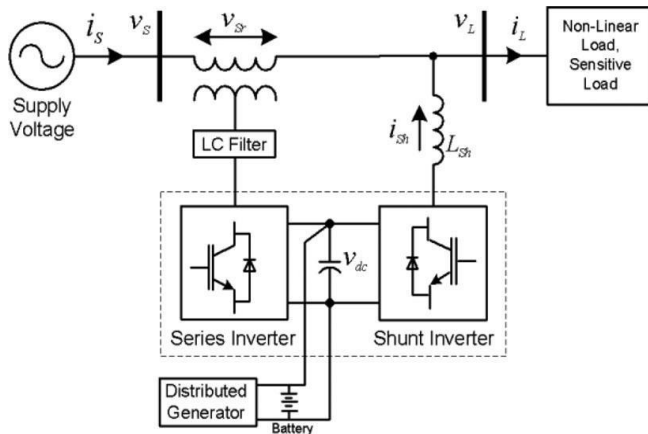

Fig. 13. System configuration of UPQC-DG

4) Compensation of voltage sag

One of the big problems of power quality is the voltage sag. For mitigating the sag in voltage the various methods by using UPQC is explained

1. Control of active power (UPQC-P)

For minimizing the sag in voltage, the active power is in use with the help of UPQC. Therefore, the name is UPQC-P.

For minimizing the sag of voltage, series inverter of UPQC supplies the component of voltage in series [24]. The supplied voltage is equal in phase and opposite in direction for minimizing the voltage sag.

2. Control of reactive power(UPQC-Q)

The control of reactive power leads to minimize the voltage sag. As it injects the reactive power from UPQC, it is called as UPQC-Q. The control of power which is reactive in the voltage of quadrature there is injection of voltage from UPQC through a series inverter [25].

3. Loading of less Volt-ampere(UPQC-VA min)

There is need of reducing the load of VA for compensation of Voltage sag. Besides the injection of series voltage in phase or in quadrature, in the minimum VA, loading voltage of optimal angle is injected. Hence, the compensation of voltage with minimum VA ampere is known as (UPQC-VA min)

4. Active and reactive power simultaneously(UPQC-S)

The working is same as that of UPQCVA_{min}. It injects the both active and reactive power [25]. The voltage sag as well as voltage swell is done simultaneously by controlling series inverter. The name is given as UPQC-S as it gives active as well as reactive power (Complex power- S).

IV. CONCLUSION

This paper resents a review of UPQC for improving the quality of electric power. Now after overall review of UPQC, the Distributed generation integrated with UPQC is main concern. In this the solar and wind i.e. renewable sources can be used, by keeping quality of power in acceptable limits. UPQC is one of the devices, which eliminates the voltage and current harmonics simultaneously. Different configurations of UPQC are briefly discussed in this paper.

REFERENCE

2002.

[3] El Habrouk M, Darwish K and P Mehta, Active power Filter: A review, IEEE Electrical power Applied, Vol. 147, no. 5, pp.403-413, sep. 2000.

[4] Babaei E, M.F. Kangarlu, Mehran Sabahi, Dynamic Voltage restorer based on multilevel Inverter with adjustable DC link; IET power Electron, Vol. 7, no. 3, pp. 576-590, 2014.

[5] Vigna K. Ramchandaramurthy, K. Chandrasekaran, "An Improved Dynamic Voltage Restorer for Power Quality Improvement", International Journal of Electrical Power and Energy Systems, vol. 82, pp. 354-362, Nov.2016.

[6] B. Singh, A. Chandra, P. Jayaprakash, K. A. Haddad, D. P. Kothari, "Comprehensive Study of DSTATCOM Configurations" IEEE Trans Ind. Informatics, vol. 10, no. 2, pp. 854-870, May 2014.

[7] P. Samal, S. Ganguly, S. Mohanty, "Effect of DSTATCOM allocation on the performance of an unbalanced radial distribution systems", IEEE conf. ICETECH, pp. 927-931, Mar. 2016.

[8] O. P. Mahela, A.G. Shaikh, " A review on Distribution Static Compensator", Renew Sustain Energy, Vol. 50, pp. 531-546, 2015.

[1] Roger Dugan, Mark McGranaghan, Beaty H.W, Electrical Power system Quality, New York: McGraw-hill, 1996.

[2] Chettur Shankaran, Power Quality, Boca Raton, FL: CRC Press,



- [9] Hirofumi Akagi, Hideaki Fujita, "A new power line conditioning for harmonic compensation in power system," *IEEE Trans. Power Delivery*, Vol. 10, no.3, pp. 1570-1575, July 1995.
- [10] Mauricio Aredes, "A combined series and shunt active power filter," in *Proc. IEEE/KTh Stockholm power Tech Conf.*, Stockholm, Sweden, pp. 18-22, June 1995.
- [11] Chen Y, Wang J, Zha X, "Unified power quality conditioner (UPQC): Theory, modeling & application" in *proc. Power system tech., Power conference*, Vol. 3, pp. 947-951, Oct. 1989.
- [12] Moran S., "A line voltage regulator –conditioner for harmonic sensitive load isolation" in *proc. Ind Applied soc. Annual meet conference*, pp. 947-951, October 1989.
- [13] Hirofumi Akagi, Hideaki Fujita, "The unified power quality conditioner: The integration of series and shunt active filter," *IEEE Trans. Power Electron*, vol 13, no. 2, pp. 315-322, Mar 1998.
- [14] D. Graovac, V. Katic, and A. Rufer, "Power quality compensation using universal power quality conditioning system," *IEEE Power Eng. Rev.*, vol. 20, no. 12, pp. 58–60, Dec. 2000.
- [15] F. Z. Peng, J.W. McKeever, and D. J. Adams, "A power line conditioner using cascade multilevel inverters for distribution systems," *IEEE Trans. Ind. Appl.*, vol. 34, no. 6, pp. 1293–1298, Nov./Dec. 1998.
- [16] M. Correa, S. Chakraborty, G. Simoes, and A. Farret, "A single phase high frequency AC microgrid with an unified power quality conditioner," in *Proc. IEEE Int. Symp. Ind. Electron.*, pp. 956–962, Jun. 9–11, 2003.
- [17] S. Chakraborty, M. Weiss, and M. Simoes, "Distributed intelligent energy management system for a single-phase high-frequency AC microgrid," *IEEE Trans. Ind. Electron.*, vol. 54, no. 1, pp. 97–109, Feb. 2007.
- [18] M. S. Khor and M. Machmoum, "A novel single-phase reduced parts on-line UPS with power quality conditioning capability," in *Proc. Power Electron. Spec. Conf.*, pp. 1170–1175, Jun. 17–21, 2007.
- [19] N. Farokhnia, S. H. Fathi, and H. R. Toodeji, "Voltage sag and unbalance mitigation in distribution systems using multi-level UPQC," in *Proc. Power Quality Conf.*, pp. 1–5, Sep. 14–15, 2010.
- [20] Jindal AK, Ghosh A, Joshi A. Interline unified power quality conditioner. *IEEE Trans Power Deliv*, pp. 364–72, 22 January 2007.
- [21] M. C. Wong, C. J. Zhan, Y. D. Han, and L. B. Zhao, "A unified approach for distribution system conditioning: Distribution system unified conditioner (DS-UniCon)," in *Proc. Power Eng. Soc. Winter Meet.*, pp. 2757–2762, Jan. 23–27, 2000.
- [22] B. Han, B. Bae, S. Baek, and G. Jang, "New configuration of UPQC for medium-voltage application," *IEEE Trans. Power Del.*, vol. 21, no. 3, pp. 1438–1444, Jul. 2006.
- [23] Davari M, Ale-Emran SM, Yazdanpanahi H, Gharehpetian G B. Modeling the combination of UPQC and photovoltaic arrays. In: *Proceedings of IEEE power systems conference and exposition*, Seattle, WA; pp.1–7, March 2009.
- [24] M. Gong, H. Liu, H. Gu, and D. Xu, "Active voltage regulator based on novel synchronization method for unbalance and fluctuation compensation," in *Proc. 28th Annu. Conf. IEEE Ind. Electron. Soc.*, pp. 1374–1379, Nov. 5-8 2002.
- [25] Vinod Khadkikar and Ambrish Chandra, "UPQC-S: A concept of voltage sag-swell and reactive power compensations by series inverter UPQC," *IEEE Trans. Power Electron.*, vol. 26, no. 9, pp. 2414–2425, Sep. 2011.